



AISI S924-20



AISI STANDARD

Test Standard for Determining the Effective Flexural Stiffness of Composite Members

2020 Edition



AISI S924-20



AISI STANDARD

Test Standard for Determining the Effective Flexural Stiffness of Composite Members

2020 Edition

Approved by
the AISI Committee on Specifications for the Design of
Cold-Formed Steel Structural Members

DISCLAIMER

The material contained herein has been developed by the American Iron and Steel Institute Committee on Specifications for the Design of Cold-Formed Steel Structural Members. The organization and the Committee have made a diligent effort to present accurate, reliable, and useful information on testing of cold-formed steel members, components, or structures. The Committee acknowledges and is grateful for the contributions of the numerous researchers, engineers, and others who have contributed to the body of knowledge on the subject. With anticipated improvements in understanding of the behavior of cold-formed steel and the continuing development of new technology, this material will become dated. It is anticipated that future editions of this test procedure will update this material as new information becomes available, but this cannot be guaranteed.

The materials set forth herein are for general information only. They are not a substitute for competent professional advice. Application of this information to a specific project should be reviewed by a registered professional engineer. Indeed, in most jurisdictions, such review is required by law. Anyone making use of the information set forth herein does so at their own risk and assumes any and all resulting liability arising therefrom.

1st Printing – December 2020

Produced by American Iron and Steel Institute

Copyright American Iron and Steel Institute 2020

PREFACE

The American Iron and Steel Institute Committee on Specifications developed this *Standard* to provide a test method for determining the flexural stiffness of composite members formed by steel deck filled with concrete.

The Committee acknowledges and is grateful for the contributions of the numerous engineers, researchers, producers and others who have contributed to the body of knowledge on this subject. Special thanks are given to Roberto Leon, J.R. Ubejd Mujagic, and members of the Composite Design Subcommittee for drafting and providing inputs to the *Standard*.

Commentaries and User Notes are non-mandatory and copyrightable portions of this *Standard*.

This Page is Intentionally Left Blank.

**AISI Committee on Specifications for the Design
of Cold-Formed Steel Structural Members**

R. B. Haws, <i>Chair</i>	Nucor Buildings Group
S. R. Fox, <i>Vice Chair</i>	Canadian Sheet Steel Building Institute
H. H. Chen, <i>Secretary</i>	American Iron and Steel Institute
D. Allen	Super Stud Building Products
H. Blum	University of Wisconsin - Madison
P. Bodwell	Verco Decking
J. Buckholt	Computerized Structural Design
S. Call	Call Engineering
J. K. Crews	Unarco Material Handling
R. S. Douglas	National Council of Structural Engineers Associations
W. S. Easterling	Iowa State University
P. W. Ford	Steel Framing Industry Association
R. S. Glauz	RSG Software
P. S. Green	Bechtel Power Corporation
P. Hainault	R. A. Smith
G. J. Hancock	University of Sydney
A. J. Harrold	Consultant
L. Kruth	American Institute of Steel Construction
Z. Li	SUNY Polytechnic Institute
R. L. Madsen	Devco Engineering
W. McRoy	ICC Evaluation Service
C. Melcher	Simpson Strong-Tie
C. Moen	RunToSolve
J. J. Pote	Steel Joist Institute
N. A. Rahman	FDR Engineers
G. Ralph	ClarkDietrich Building Systems
V. E. Sagan	Metal Building Manufacturers Association
T. Samiappan	Quick Tie Products
B. W. Schafer	Johns Hopkins University
T. Sputo	Steel Deck Institute
M. Tancredi	Ferroeng Group
S. Torabian	Cold-Formed Steel Research Consortium
C. Yu	University of North Texas
R. Zadeh	RAZ Tech
R. Ziemian	Structural Stability Research Council

Subcommittee 6 – Test-Based Design

K. Peterman, <i>Chair</i>	University of Massachusetts Amherst
H. H. Chen, <i>Secretary</i>	American Iron and Steel Institute
R. S. Douglas	National Council of Structural Engineers Associations
D. Fox	iSPAN Systems
S. R. Fox	Canadian Sheet Steel Building Institute
P. S. Green	Bechtel Power Corporation
R. B. Haws	Nucor Buildings Group
R. L. Madsen	Devco Engineering
J. R. Martin	Verco Decking
C. Moen	RunToSolve
N. A. Rahman	FDR Engineering
G. Ralph	ClarkDietrich Building Systems
V. E. Sagan	Metal Building Manufacturers Association
T. Samiappan	Quick Tie Products
B. W. Schafer	Johns Hopkins University
M. Schmeida	Gypsum Association
F. Sesma	California Expanded Metal Products
M. Speicher	NIST Engineering Laboratory
T. Sputo	Steel Deck Institute
S. Torabian	Cold-Formed Steel Research Consortium
C. Yu	University of North Texas

AISI S924-20
TEST STANDARD FOR
DETERMINING THE EFFECTIVE FLEXURAL STIFFNESS
OF COMPOSITE MEMBERS

1. Scope

1.1 This *Standard* establishes a test method for determining the effective flexural stiffness of flexural composite members.

Commentary:

This *Standard* can be used to determine the effective flexural stiffness $(EI)_{\text{eff}}$ of composite members made with cold-formed steel and conventional normalweight or lightweight concrete. Although the *Standard* was written with steel deck and similar composite floor systems in mind, it can be used for all types of composite members provided the load introduction is through the concrete. The effective flexural properties can be used in determining the deflection and member stability, and other calculations requiring the use of an elastic effective stiffness.

2. Referenced Documents

The following documents or portions thereof are referenced within this *Standard* and shall be considered as part of the requirements of this document.

a. American Concrete Society (ACI), Farmington Hills, MI:

ACI 318-19, *Building Code Requirements for Structural Concrete*

ACI 301-16, *Specification for Structural Concrete*

b. American Iron and Steel Institute (AISI), Washington, DC:

S100-16(2020) w/S2-20, *North American Specification for the Design of Cold-Formed Steel Structural Members With Supplement 2*

S923-20, *Test Standard for Determining the Strength and Stiffness of Shear Connections of Composite Members*

c. ASTM International (ASTM), West Conshohocken, PA:

A90/A90M-13(2018), *Standard Test Method for Weight [Mass] of Coating on Iron and Steel Articles With Zinc or Zinc-Alloy Coatings*

A123/A123M-17, *Standard Specification for Zinc (Hot-Dip Galvanized) Coatings on Iron and Steel Products*

A653/A653M-19a, *Standard Specification for Steel Sheet, Zinc-Coated (Galvanized) or Zinc-Iron Alloy-Coated (Galvannealed) by the Hot-Dip Process*

A370-20, *Standard Test Methods and Definitions for Mechanical Testing of Steel Products*

C138/C138M-17a, *Standard Test Method for Density (Unit Weight), Yield, and Air Content (Gravimetric) of Concrete*

E6-15e2, *Standard Terminology Relating to Methods of Mechanical Testing*

IEEE/ASTM SI10-16, *American National Standard for Metric Practice*

3. Terminology

Where the following terms appear in this *Standard*, they shall have the meaning as defined herein. Terms not defined in Section 3 of this *Standard*, AISI S100 or ASTM E6 shall have the ordinary accepted meaning for the context for which they are intended.

Effective Flexural Stiffness of a Composite Member. Average stiffness of the three loading and unloading deflection cycles between displacement of $L/1000$ and $L/360$, where L is the clear span between supports.

User Note:

The elastic stiffness is computed using the slope of the load-deformation curve adjusted for the type and positioning of the loads. The test described in this *Standard* uses a symmetric placement of two-point loads for which the stiffness is calculated as:

$$(EI)_{\text{eff}} = \frac{23L^3}{648} \frac{dP}{d\Delta} \quad (\text{Eq. 1})$$

4. Symbols

- a = Distance between support and loading point (see Figure 1)
- b = Distance between two loading points (see Figure 1)
- $(EI)_{\text{eff}}$ = *Effective flexural stiffness of a composite member*
- L = Span length (see Figure 1)
- P = Applied test load (see Figure 1)
- W = Slab width (see Figure 2)
- Δ = Vertical deformation (see Figure 3)
- Δ_{SLS} = Vertical deformation corresponding to service load deflection limit ($L/360$ unless otherwise specified, where “SLS” stands for “Serviceability Limit State.”)
- Δ_y = Vertical deformation when stiffness first drops below 5% of $(EI)_{\text{eff}}$

5. Units of Symbols and Terms

Any compatible system of measurement units is permitted to be used in this *Standard*, except where explicitly stated otherwise. The unit systems considered in this *Standard* shall include U.S. Customary units (force in kips and length in inches) and SI units (force in Newtons and length in millimeters) in accordance with IEEE/ASTM SI10.

6. Measurements, Precision and Control

6.1 Minimum instrumentation shall consist of one force and at least two deflection-measuring devices capable of outputting digital signals to a data acquisition system. One deflection transducer shall have a range of at least $3\Delta_{\text{SLS}}$ for stiffness measurements and the other shall have a range of $20\Delta_{\text{SLS}}$ or $L/16$ for strength measurements.

User Note:

The instrumentation will consist of at least one load cell and two deflection transducers. The load cell should have a capacity at least 1.5 times the expected maximum load. Typically, the shorter measuring device will be a high-precision displacement transducer while the longer device will be a string potentiometer or similar. The intent is to capture deformation behavior in the elastic range and strength and deformation behavior up to failure. Note that the $L/16$ also represents a minimum stroke for the loading actuator. The use of additional instrumentation, in the form of end slip deformation devices, strain gauges on the steel and/or concrete at centerline and similar, is encouraged to provide additional data for calibration of potential analytical models. The *Standard* is written for the case of a simply-supported specimen; if two- or three-span specimens are used, additional load cells under the supports will be needed as the specimen will be statically indeterminate.

6.2 Loads and deformations shall be recorded to a precision of 0.25% of the expected maximum load, and deflections shall be recorded to a precision of 0.5% of Δ_{SLS} for stiffness measurements and 1.0% of Δ_y for strength measurements.

Commentary:

The instrumentation is intended to produce: (1) an accurate load-deformation curve in the elastic range from which the flexural stiffness of the system can be obtained ($L/240$ is nominally adopted as the limit of elastic action in this *Standard* with a measurement device capable of resolving 0.5% over that displacement range), and (2) a complete characterization of the load-deformation behavior to characterize failure modes as well as ultimate strength and deformation capacity. The range of the measuring devices should be appropriate to the expected maximum values in the test and the data acquisition capabilities. Calibration and traceability information for the devices should be provided as part of the test report. Information on how to satisfy these requirements can be found in standards such as ASTM E74, ASTM E2309/E2309M and E4.

References:

ASTM E4-20, *Standard Practices for Force Verification of Testing Machines*
ASTM E74-18e1, *Standard Practices for Calibration and Verification for Force-Measuring Instruments*
ASTM E2309/E2309M-20, *Standard Practices for Verification of Displacement Measuring Systems and Devices Used in Material Testing Machines*

6.3 The test shall incorporate a deflection control system capable of applying loads at constant strain rates on the extreme fiber of the concrete portions of the specimens ranging between 0.002 in./in. per minute and 0.02 in./in. per minute.

User Note:

The test must be run in deflection control mode for proper determination of stiffness and thus needs to be run at strain rates similar to those used to determine modulus of elasticity in common structural materials. The loading rate may be controlled through the manual controls of the loading device, a servo-hydraulic controller tied to a loading cylinder, or similar arrangement. The limits given above correspond to displacement rates roughly 0.1 in./min. (2.5 mm/min.) and 1 in./min. (25 mm/min) for most practical situations.

6.4 The test shall incorporate a digital data acquisition system capable of recording at least 100 readings between $L/1000$ and $L/240$ at the strain rates prescribed in Section 6.3.

7. Test Fixture

7.1 The test fixture shall consist of a testing machine or frame with an axial rigidity at least 20 times that of the tested specimen unless the test machine or test frame deformations are measured and this effect is incorporated into the calculations.

Commentary:

Contrary to the case of testing for strength, testing for stiffness requires that the loading frame be very rigid in comparison to the specimen to obtain proper results. To determine this, a steel beam of similar rigidity to the test specimen can be placed in the test setup and loaded to a deflection of 1 in.; a deflection device on the test setup immediately above the support of the loading device shall record a deflection of 0.05 in. or less. Alternatively, a structural analysis with appropriate modeling for members and connections can be used.

7.2 The test setup shall be as illustrated in Figures 1 and 2. The pin and roller supports shall be designed to minimize friction, and there shall be contact between the support and the specimen for at least 80% of its width. The transverse line loads shall extend for at least 75% of the width of the slab. Provisions shall be made for appropriate clearance between the specimen and the loading frame at ultimate.

Commentary:

There are many ways of providing the pin and roller support conditions required; the *Standard* only requires that friction be minimized. It is recommended that dial gauges or similar devices be used to monitor horizontal displacement of the test supports to ensure that idealized support conditions are maintained through the test. A minimum clearance of $L/15$ should be sufficient.

This *Standard* is meant for single-span specimens. The test fixture can be extended to two- or three-span specimens provided additional instrumentation is provided.

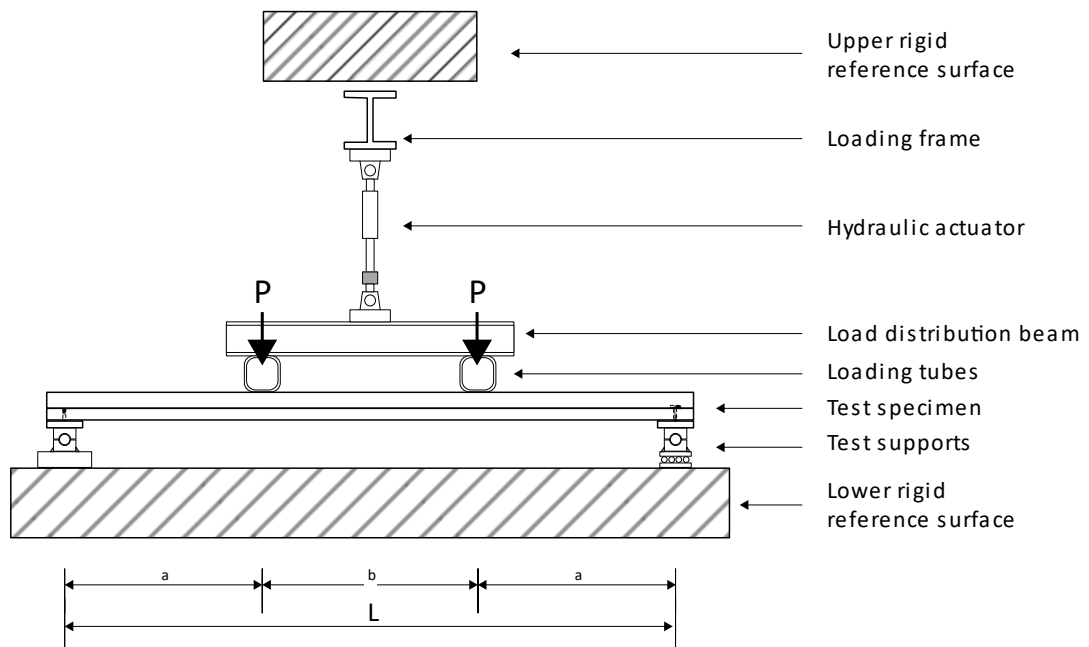

Figure 1 - Elevation of Test Fixture and Member

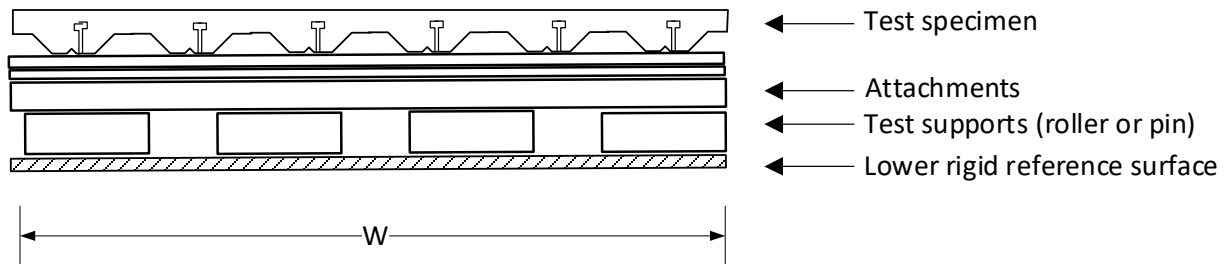

Figure 2 - Section of Test Fixture and Member

7.3 The lateral support fixtures used in the test shall be installed in such a manner so as not to impede the horizontal displacement of the open side of the section, i.e., the compression flanges and the vertical deflection of the specimen.

Commentary:

In a stiffness test of the type described in this document, minimizing all sources of extraneous restraint is the key to reproducibility and minimizing data scatter. It is recommended, at a minimum, that any surfaces in contact be coated with a Teflon™-like material.

8. Test Specimen

8.1 Number of Tests. A test unit shall include a minimum of three nominally identical composite member specimens.

8.2 Shear Connection. All pertinent dimensions, such as length, width, thickness, shear connector spacing, and radius of bent components, shall be measured and reported on each unique configuration. As a minimum, the requirements of AISI S923 shall be met.

8.3 Base Steel. Testing of sample material from all steel components that form part of the specimen shall be conducted to ensure compliance with the applicable material standard.

User Note:

Required material properties specified by the applicable ASTM standard must be documented. Material test reports from the manufacturer of the heat of steel utilized to produce the specimen steel components are an acceptable alternative, provided traceability is verified.

The steel yield strength, tensile strength, elongation, and area of reduction shall be determined in accordance with ASTM A370. The dimensions of the supporting steel, including base steel thickness, shall be measured. Coating weight and thickness shall be determined in accordance with ASTM A90, A123 or A653.

8.4 Steel Deck. When steel deck is used in any particular configuration, for each deck profile, geometrical dimensions such as depth of the steel deck profile, top flange width, web width, bottom flange width, and average concrete rib width shall be measured. Longitudinal tensile specimens shall be cut from the center of the widest flat of a formed section from which the member specimens have been taken, or the tensile specimens shall be taken from the sheet or coil material used for the fabrication of the member specimens. The tensile specimens shall not be taken from parts of a previously tested deck.

8.5 Concrete. Concrete testing, mix, and proportions shall conform to the requirements of ACI 301. Strength tests shall be the average of the strengths of at least two cylinders made from the same sample of concrete. Two strength tests shall be performed, and the average compressive strength reported. The two strength tests shall be conducted such that one test is within a 24-hour period immediately preceding and the other test immediately after the flexural test series (minimum four cylinders). Each configuration of replicate test specimens shall be specific to a single nominal concrete weight (i.e., normalweight, lightweight, or sand-lightweight) and the concrete weight shall be determined as defined in accordance with ASTM C138/C138M and recorded.

8.6 Reinforcing Steel. Structural reinforcing, as applicable, shall conform to ACI 318 or other applicable standard.

9. Test Setup

9.1 Distance between loading points, b , as shown in Figure 1, shall be one-third of the span length and the effective stiffness shall be determined in accordance with the deflection measured at the mid-span.

9.2 Member test specimens shall be cut from the commercially fabricated product or member test specimens shall be specially fabricated to represent the commercially fabricated product.

10. Test Procedure

10.1 A two-point load shall be applied to the system to produce compression in the concrete surface of the test specimen (See Figure 1).

10.2 The specimen shall be centered on the axis of the loading device.

10.3 The test shall be run in deflection control utilizing the following protocol (Figure 3):

1. Apply 3 cycles of deformation at a deflection of $L/1000$ at a speed of 0.2 in./min. (5.1 mm/min.) to shakedown the system (Stage 1).
2. Apply a deformation of $L/480$ and hold deformation for 5 minutes (Stage 2).
3. Unload and reload for 3 cycles at $L/240$ at a load rate of 0.2 in./min. (5.1 mm/min.) (Stage 3).
4. Conduct a preliminary evaluation of the loading and unloading slopes as shown in Figure 3. The slopes are those of secant lines between the $L/1000$ and $L/360$ limits. If the slopes are continuously decreasing and changing by more than 5%, more cycles are applied until that criteria is met.
5. Apply three cycles at $L/120$, $L/60$ and $L/24$ at a rate of 0.5 in./min. (13 mm/min.) (Stages 4 through 6).
6. Load to failure at a rate of 0.5 in./min. (13 mm/min.) (Stage 7).

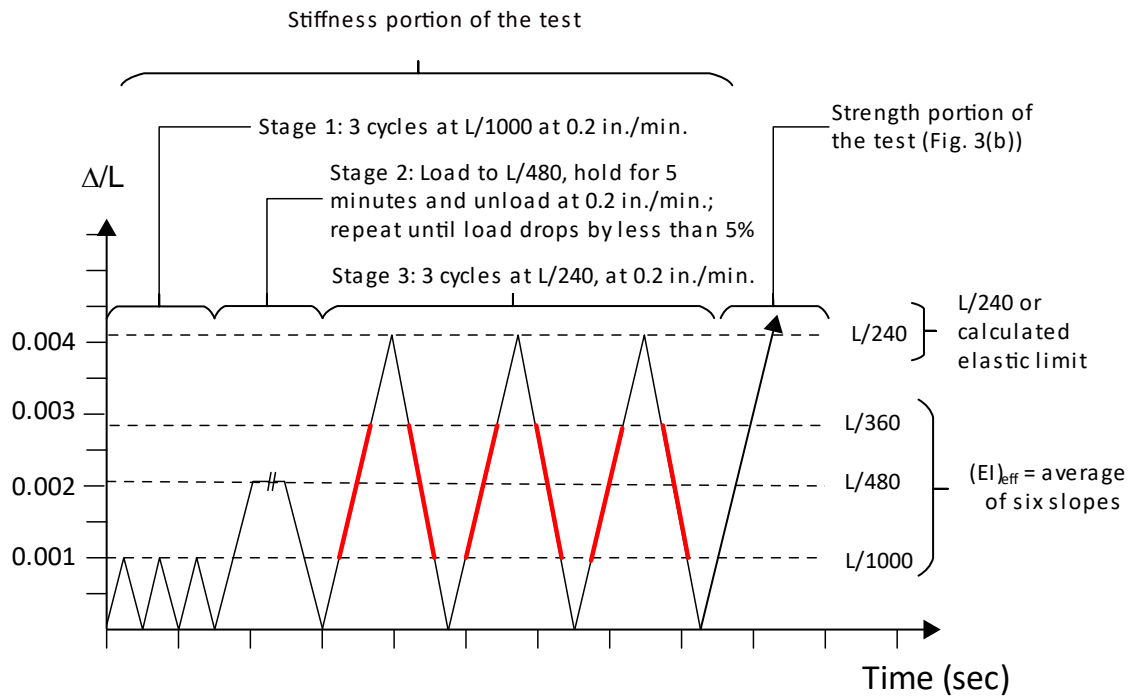

(a) Stiffness Portion of Test

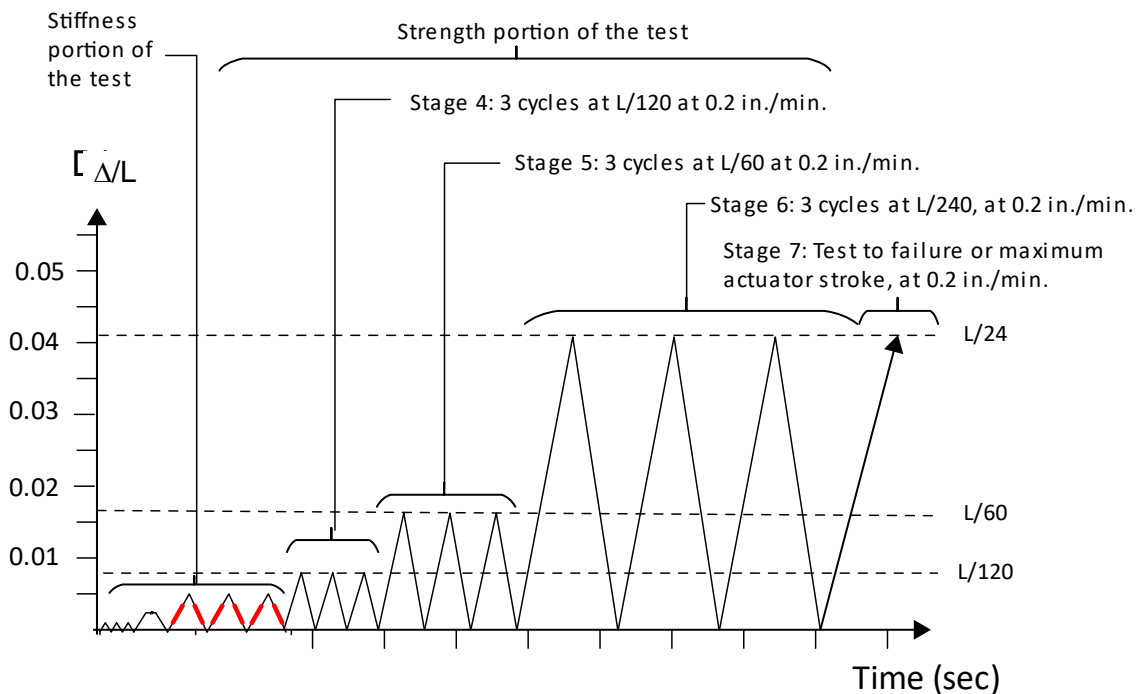

(b) Strength Portion of Test

Figure 3 – Deflection Protocol

Commentary:

Stage 1 is a shakedown series of cycles, intending to remove extraneous sources of deformation and improve the contact conditions for the specimen.

Stage 2 is a short-term test intended to eliminate any sources of creep and ensure the capacity of the system to maintain load and deformation. This test step shall be repeated until the load drops by no more than 5% during the 5-minute period.

Stage 3 is used to derive an equivalent secant stiffness between deflections at $L/1000$ and $L/360$.

A preliminary evaluation of the slopes should be done after Stage 3; if the slopes are continuously decreasing and changing by more than 5%, more cycles should be applied until that criteria is met.

Stages 4 through 6 are used to determine the degradation of the stiffness in the inelastic range.

In Stage 7, the specimen is tested to either failure, defined as a reduction of strength to 80% of ultimate, or the stroke capacity of the loading apparatus is reached.

10.4 Loads and deflections of the specimen shall be measured continuously during the test within the tolerances specified in Section 6.

11. Data Evaluation

11.1 The *effective flexural stiffness of a composite member* $(EI)_{\text{eff}}$ shall be computed using the three deflection cycles between the $L/1000$ and $L/360$ deflections. The coefficient of variation (COV) from the six values shall not exceed 0.15.

12. Test Report

12.1 The report shall include a complete record of the sources for the materials of the members tested, their applicable ASTM conformance standards, and the location and number of any material test specimens taken. It shall describe whether the specimens were taken from one or several members, or several production runs, coil stock, or other sources.

12.2 The documentation shall include all measurements taken for each member test specimen, including: (1) cross-section dimensions, (2) uncoated sheet thickness, (3) yield stress, (4) tensile strength, (5) percent elongation, (6) applicable material specification, (7) manufacturer, (8) test setup characteristics such as lateral brace locations and bearing stiffeners, and (9) evaluation procedure used.

12.3 The determination of the selected member span shall be fully documented with appropriate calculations. A minimum span-to-depth ratio of 8 shall be used.

12.4 A complete description of the test setup, instruments, data acquisition system, and associated calibrations shall be included.

12.5 The report shall include the complete load-deformation curves, shown in separate plots to where the stiffness has decreased to one-half of $(EI)_{\text{eff}}$ and to ultimate deflection, plots showing the calculations of the secant stiffness, and observations made during the test for each member tested.

12.6 The report shall include a table that reports, at a minimum:

1. The load and deformation at Δ_{SLS} ,

2. The load and deformation at the peak of each cycle and any residual deformation after each cycle, and
3. The maximum load and corresponding deformation; this can be taken as the flexural strength of the specimen.

12.7 The report shall state any visual observations recorded that are pertinent to the performance of the test specimen(s).

12.8 The report shall provide the data required (number of tests, coefficient of variation of the test load, etc.) for the determination of resistance factor, ϕ , and safety factor, Ω , in accordance with Section K2.1 of AISI S100.



25 Massachusetts Avenue NW
Suite 800
Washington, DC 20001
www.steel.org





**American
Iron and Steel
Institute**

25 Massachusetts Avenue NW
Suite 800
Washington, DC 20001
www.steel.org

